

BACKGROUND

An aluminum pop can be approximated by a long thin-walled cylinder with end caps under internal pressure. As such, it is a structure similar to that found in SCUBA tanks, water and gas pipelines, fuel tanks in liquid-propellant rockets and pneumatic and hydraulic lines in machinery.

The objective of this lab is to determine the pressure in a typical aluminum pop can. This pressure will be determined using a strain-gaged can. Strain readings will be used in conjunction with strain transformation, Hooke's law and thin-walled pressure vessel theory to determine the internal pressure in a can prior to and after opening.

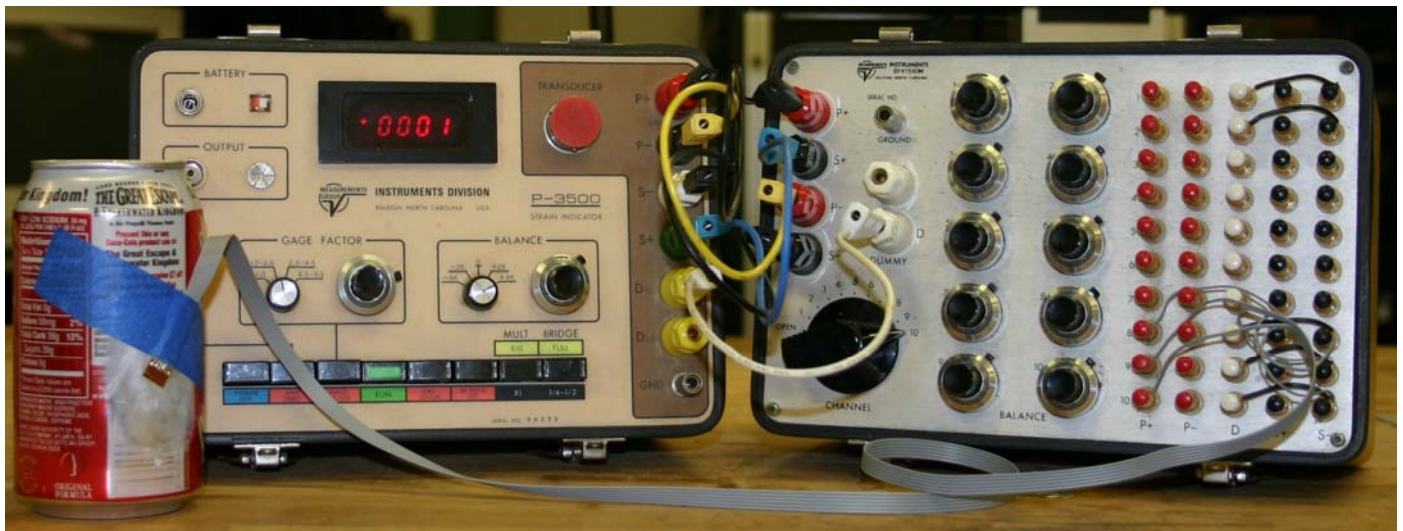

TEST PROCEDURE

1. Obtain a strain-gaged pop can from instructor.
2. Connect wires as shown to complete the quarter-bridge circuit.
3. Zero the amplifier using the AMP ZERO pot.
4. Enter the gage factor from the strain gage manufacturer's data sheet (2.07 for these gages).
5. Zero the strain readings for each channel using the BALANCE pot.
6. Record existing strains for each channel (which should be zero or very close to zero).
7. Open can.
8. Record strains again.
9. Measure the misalignment angle the strain gage makes with the longitudinal axis of the can.

Shake one can and note the strains. What is expected? Do not open this can.

DATA ANALYSIS AND REPORTING

1. Prepare a table of the experimental results.
2. Determine the internal pressure that was in the can.
3. Prepare a two page maximum type-set report that includes a title and author at the top.

REDUCTION OF RECTANGULAR ROSETTE STRAIN GAGE DATA

A rectangular rosette consists of three strain gages arranged at 45° from each other, as shown in the figure. The gages are labeled *a*, *b* and *c*, and the strains recorded by each are $\hat{\epsilon}_a$, $\hat{\epsilon}_b$ and $\hat{\epsilon}_c$, respectively. The rosette resides in a region of biaxial stress on the outside surface of the pop can, and the recorded strains

must be corrected for their sensitivity to transverse strain (i.e., the Poisson effect). A transverse sensitivity *k* for each gage in the rosette is provided on the manufacturer's data sheet, and, for the rosettes of this lab, $k = 0.0012$, determined using 2024-T4 aluminum as the substrate, for which the Poisson's ratio $\nu_s = 0.33$. The corrected strains can be shown to be given by

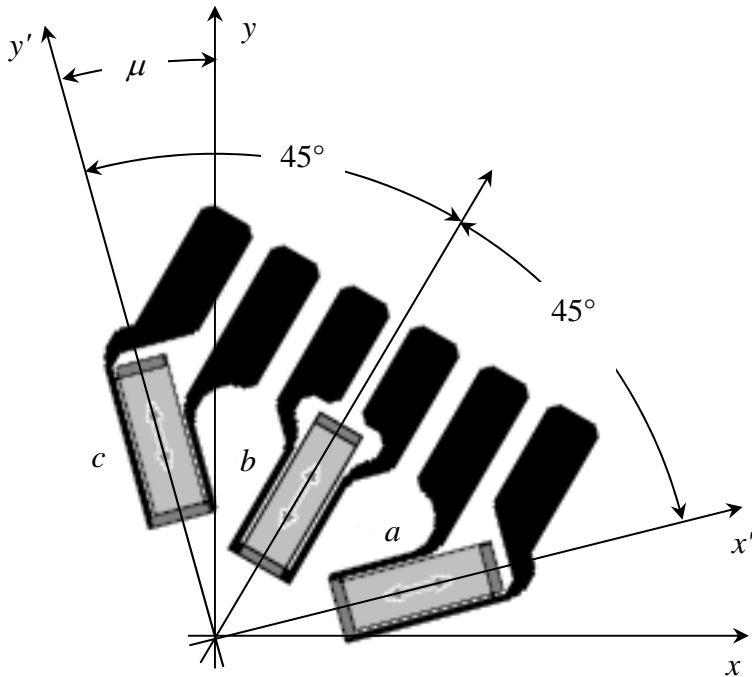

$$\epsilon_a = \frac{(1 - \nu_s k)}{1 - k^2} (\hat{\epsilon}_a - k \hat{\epsilon}_c)$$

$$\epsilon_b = \frac{(1 - \nu_s k)}{1 - k} \left[\hat{\epsilon}_b - \frac{1 - k}{1 - k^2} (\hat{\epsilon}_c + k \hat{\epsilon}_a) \right]$$

$$\epsilon_c = \frac{(1 - \nu_s k)}{1 - k^2} (\hat{\epsilon}_c - k \hat{\epsilon}_a)$$

The gages have been purposely misaligned by a gross amount, the misalignment angle μ . However, even with the most meticulous of methods, a precise alignment is nearly impossible. Therefore, accounting for this misalignment is a useful exercise. Strain transformation must be used to transform the corrected strains in the primed (misaligned) system to the unprimed (aligned) system, which results in

$$\begin{bmatrix} \cos^2 \mu & \sin^2 \mu & \sin \mu \cos \mu \\ \cos^2 (\mu + 45^\circ) & \sin^2 (\mu + 45^\circ) & \sin (\mu + 45^\circ) \cos (\mu + 45^\circ) \\ \cos^2 (\mu + 90^\circ) & \sin^2 (\mu + 90^\circ) & \sin (\mu + 90^\circ) \cos (\mu + 90^\circ) \end{bmatrix} \begin{bmatrix} \epsilon_x \\ \epsilon_y \\ \gamma_{xy} \end{bmatrix} = \begin{bmatrix} \epsilon_a \\ \epsilon_b \\ \epsilon_c \end{bmatrix}$$

The principal in-plane strains, again using strain transformation, can now be determined from

$$\epsilon_{\max, \min} = \frac{1}{2} (\epsilon_x + \epsilon_y) \pm \frac{1}{2} \sqrt{(\epsilon_x - \epsilon_y)^2 + \gamma_{xy}^2}$$

and the principal orientations from

$$\tan 2\theta_p = \frac{\gamma_{xy}}{\epsilon_x - \epsilon_y}$$

These principal strains can be related to the principal stresses via Hooke's law

$$\begin{bmatrix} 1 & -\nu \\ -\nu & 1 \end{bmatrix} \begin{bmatrix} \sigma_{\max} \\ \sigma_{\min} \end{bmatrix} = E \begin{bmatrix} \varepsilon_{\max} \\ \varepsilon_{\min} \end{bmatrix}$$

where the Poisson's ratio ν and Young's modulus E are of the pop can material. An equilibrium analysis of a long cylindrical pressure vessel reveals that the principal stresses are related to the internal pressure p in the vessel, the inner radius r and the wall thickness t as in

$$|\sigma_{\max}| = 2|\sigma_{\min}| = \frac{pr}{t}$$

Therefore, the internal pressure can now be determined from the above relations and either

$$p_{\sigma_{\max}} = \left| \frac{t}{r} \frac{E}{1-\nu^2} (\varepsilon_{\max} + \nu\varepsilon_{\min}) \right| \quad \text{or} \quad p_{\sigma_{\min}} = \left| \frac{2t}{r} \frac{E}{1-\nu^2} (\nu\varepsilon_{\max} + \varepsilon_{\min}) \right|$$

The subscripts indicate from which principal stress the pressure was determined. The absolute value bars appear because the gages were installed and "zeroed" on the cans in their pressurized state, and then the pressure released, thereby causing the walls to contract to give negative strain readings.

REMARKS ON THIN-WALLED PRESSURE VESSELS

The stress formulas developed for thin-walled cylindrical pressure vessels do not exactly replicate actual vessels. The formulas produce errors less than 5% relative to an exact solution as long as the internal radius is ten times the wall thickness (cf. Cook RD, Young WC. Advanced mechanics of materials. 2e. Prentice Hall 1999.). Stress concentrations and three dimensional stress states exist near end caps of finite length closed vessels; by Saint-Venant's principle, the stress state on the outside surface is nearly biaxial at a distance of one to two inner radii from the end caps. Finally, it should be noted that the stress state is definitely triaxial on the inside surface of the vessel due to the internal pressure.

POP CAN MATERIAL

The aluminum of a typical pop can is usually in the 1000 series (1050, 1060, 1070 or 80) and strain-hardened from H12 to H18. This information comes from a highly reliable source at one of our nation's preeminent recycling and raw material management companies (simsmm.com). Elastic properties for some of these aluminums can be found in a variety of sources including matweb.com.